



## Spiral Bar Coater

### AB3050

Stainless steel Spiral applicators, with a film width of 180, 230 or 320 mm, are round bars, tightly wound with stainless steel wire. The diameter of the wire, in the wound form, regulates the thickness of the coating. The Spiral applicator is ideal for application of (thin) film of thin materials such as sheet of paper or plastic. Also to be used with automatic film applicators.

This type of spiral bar coater fits on the TQC / TQC Sheen Automatic Film Applicator Models, sold from 2012 and on. If you have an older model TQC Automatic Film Applicator, another type of spiral film applicator (starting with article code VF...) has to be used. Please contact us for availability.

## Business

Paint laboratory

## Standards

Look up the appropriate standard for a correct execution of the test.

## Scope of supply

The Spiral Bar coater comes in a tube-type case.

## Specifications

- Material Stainless steel
- Available in sizes from 4 to 300  $\mu\text{m}$
- Straightness < 50  $\mu\text{m}$

## Use

The DC9000 Hull Roughness Gauge has a menu-driven interface. Check the manual for full details.

## Special care

- Though robust in design, this instrument is precision-machined. Never drop it or knock it over
- Always clean the instrument after use.
- Only use non-corrosive solvents to clean the instrument. Use a soft, non-abrasive cloth to dry it.
- Never clean the instrument by any mechanical means such as a wire brush or abrasive paper. This may cause, just like the use of aggressive cleaning agents, permanent damage.
- When stored for a long period of time, wrap the instrument in oil paper

## Ordering information

Film thickness	Film width		
	180mm	230mm	320mm
0 $\mu\text{m}$	SH0632	AB3742	AB3070
4 $\mu\text{m}$	SH0168	SB3720	AB3050
6 $\mu\text{m}$	SH0232	AB3721	AB3051
8 $\mu\text{m}$	SH0262	AB3722	AB3052
10 $\mu\text{m}$	SH0631	AB3723	AB3053
12 $\mu\text{m}$	SH0676	AB3724	AB3054
14 $\mu\text{m}$	SH0700	AB3725	AB3055
16 $\mu\text{m}$	SH0728	AB3726	AB3056
18 $\mu\text{m}$	SH0751	AB3743	AB3082
20 $\mu\text{m}$	SH0799	AB3727	AB3057
24 $\mu\text{m}$	SH0856	AB3728	AB3058
26 $\mu\text{m}$	SH0897	AB3744	AB3083
28 $\mu\text{m}$	SH0921	AB3745	AB3084
30 $\mu\text{m}$	SH0941	AB3729	AB3059
32 $\mu\text{m}$	SH0965	AB3746	AB3085
34 $\mu\text{m}$	SH0978	AB3730	AB3060
36 $\mu\text{m}$	SH0994	AB3747	AB3086
38 $\mu\text{m}$	SH1018	AB3731	AB3061
40 $\mu\text{m}$	SH1042	AB3732	AB3062
46 $\mu\text{m}$	SH1091	AB3748	AB3087
48 $\mu\text{m}$	SH8007	AB3749	AB3088
50 $\mu\text{m}$	SH1144	AB3733	AB3063
56 $\mu\text{m}$	SH1216	AB3734	AB3064
60 $\mu\text{m}$	SH1231	AB3735	AB3065
66 $\mu\text{m}$	SH1266	AB3750	AB3089
70 $\mu\text{m}$	SH1280	AB3751	AB3094
76 $\mu\text{m}$	SH1314	AB3736	AB3066
80 $\mu\text{m}$	SH1341	AB3752	AB3095
88 $\mu\text{m}$	SH1372	AB3753	AB3096

Film thickness	Film width		
	180mm	230mm	320mm
100 $\mu\text{m}$	SH0326	AB3736	AB3067
120 $\mu\text{m}$	SH0797	AB3738	AB3068
128 $\mu\text{m}$	SH0919	AB3754	AB3097
150 $\mu\text{m}$	SH1686	AB3739	AB3072
200 $\mu\text{m}$	SH0329	AB3740	AB3069
300 $\mu\text{m}$	SH0338	AB3755	AB3099
Custom	SH2005	AB3741	AB3071

### Accessories

- VF1601** Application Table 380 x 230 mm
- VF1602** Application Table 230 x 160 mm
- VF2343** Test charts A6, White/Black B+, with optical brightner, 250pcs
- VF2344** Test charts A5, White/Black B+, with optical brightner, 250pcs
- VF2345** Test charts A4, White/Black B+, with optical brightner, 250pcs
- VF2346** Test charts A5, Black/White chequered B+, with optical brightner, 250pcs
- VF2347** Test charts A4, Black/White chequered B+, with optical brightner, 250pcs
- VF2354** Test charts A3, Black/White chequered B+, with optical brightner, 250pcs
- VF2317** Test charts A6, White/Black B-, without optical brightner, 250pcs
- VF2319** Test charts A5, White/Black B-, without optical brightner, 250pcs
- VF2321** Test charts A4, White/Black B-, without optical brightner, 250pcs
- VF2323** Test charts A5, Black/White chequered B-, without optical brightner, 250pcs
- VF2325** Test charts A4, Black/White chequered B-, without optical brightner, 250pcs

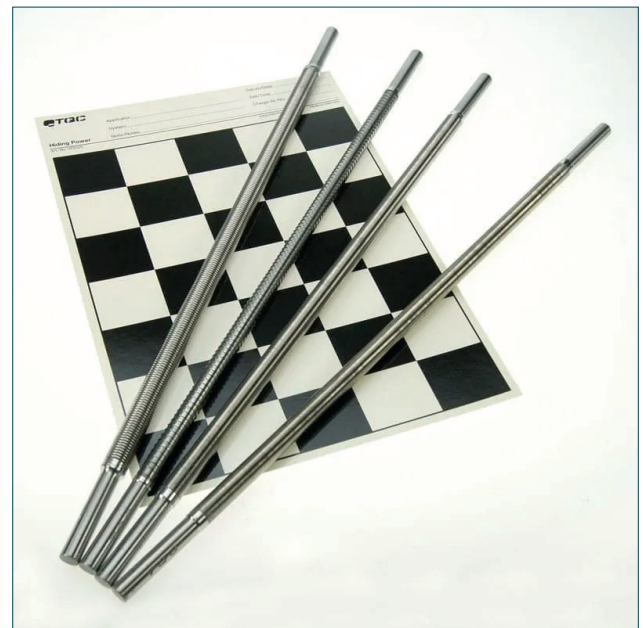
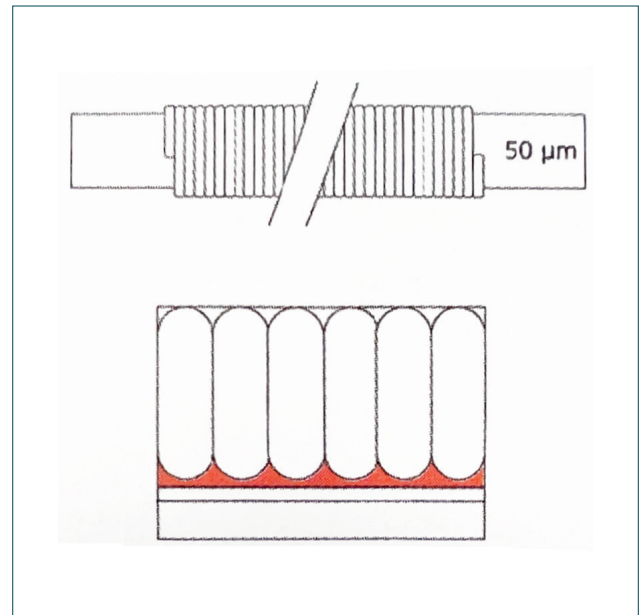

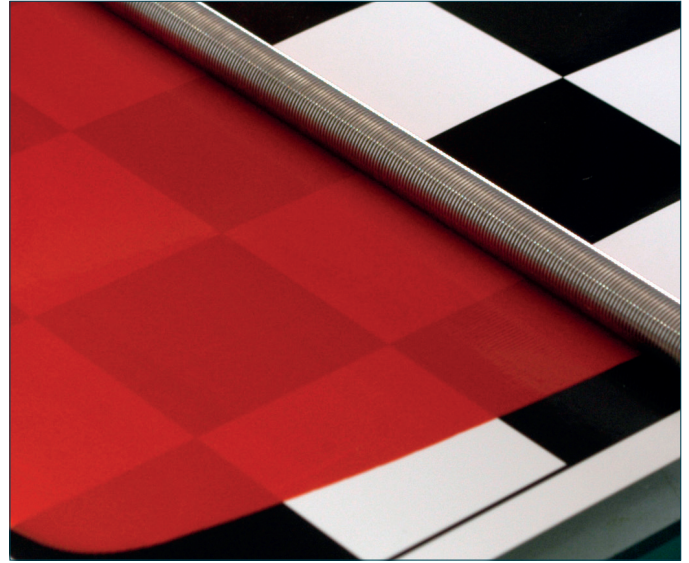

### Automatic Film Applicator Standard

The Automatic film applicator provides a reliable basis to apply coating films to test charts, panels or foils. A heated model is also available.



### Contact Details

web. [www.industrialphysics.com](http://www.industrialphysics.com)

email. [info@industrialphysics.com](mailto:info@industrialphysics.com)

email. [info-ic@industrialphysics.com](mailto:info-ic@industrialphysics.com)